

- Pin hole $\varnothing 24 \times 14$ bore
- Eject hole $\varnothing 24 \times 10$ bore

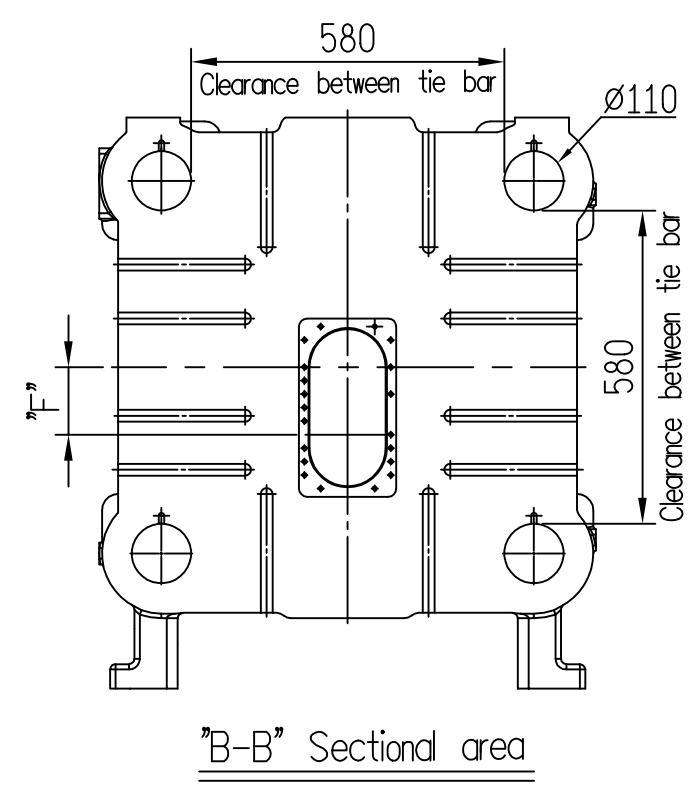
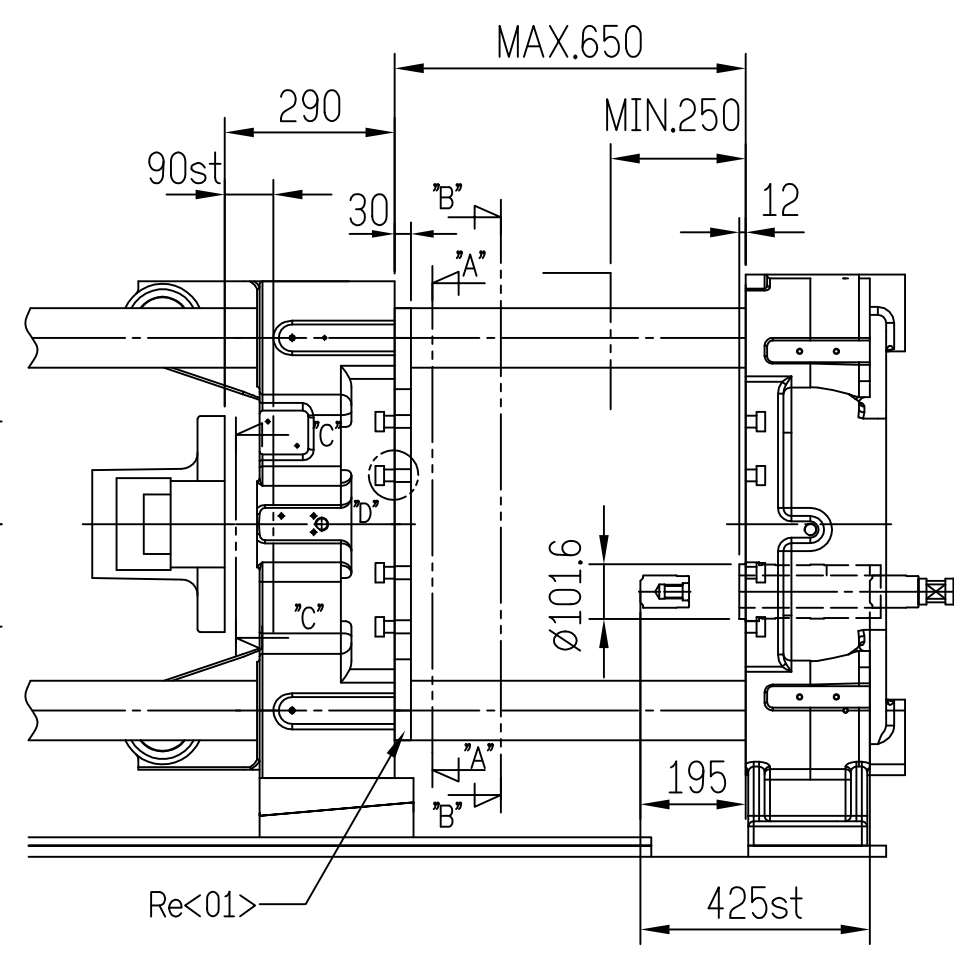
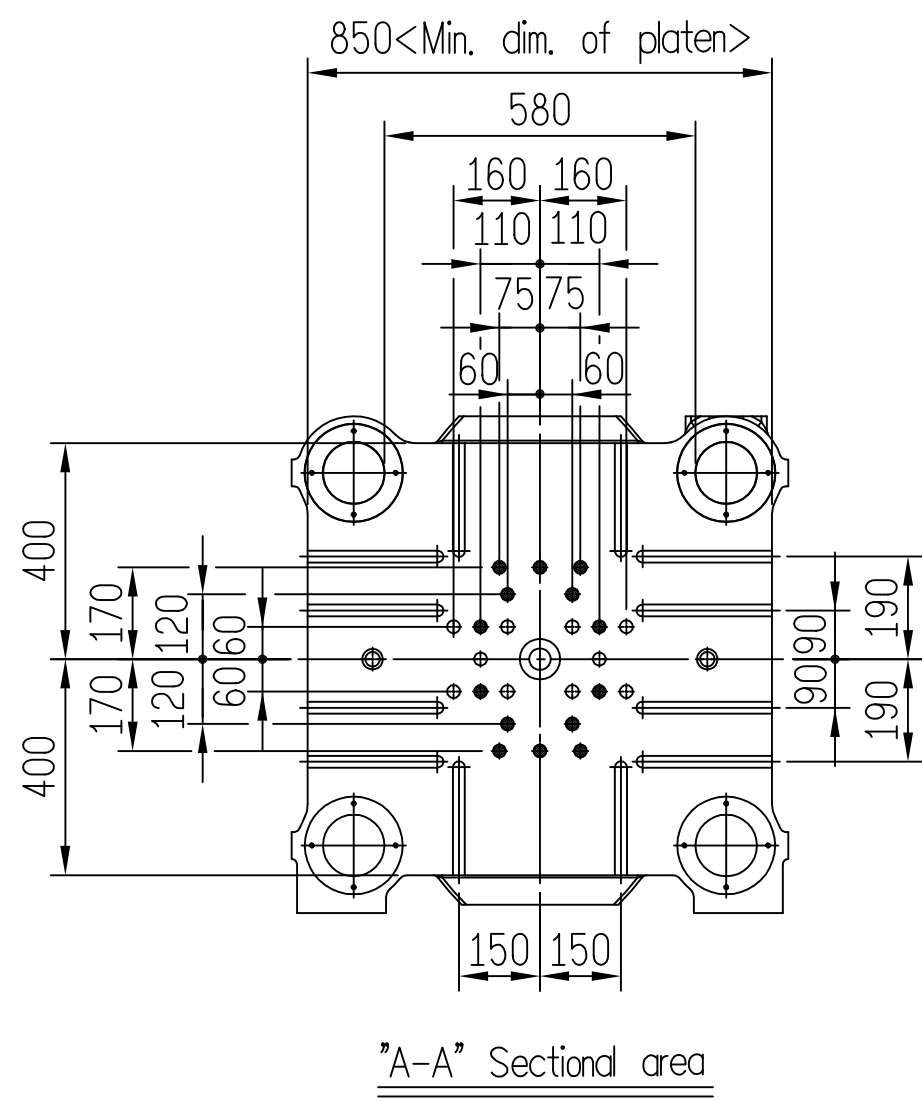
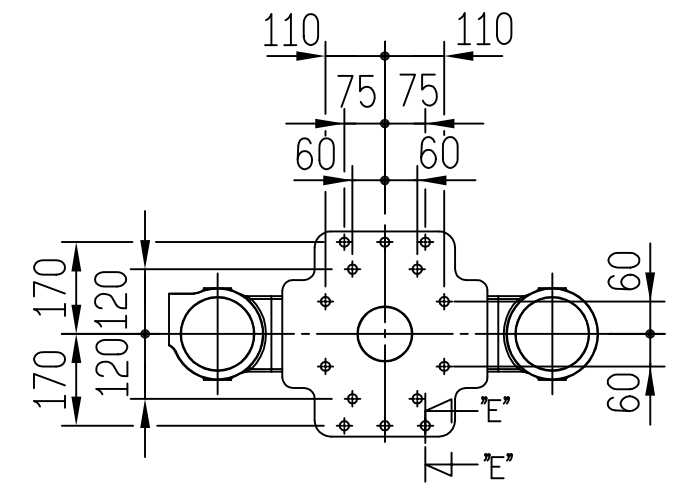
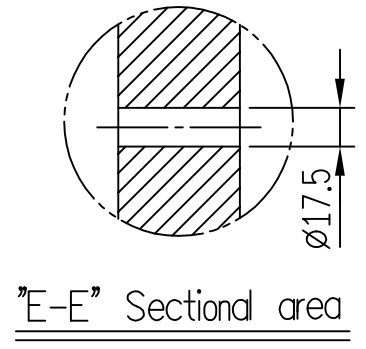
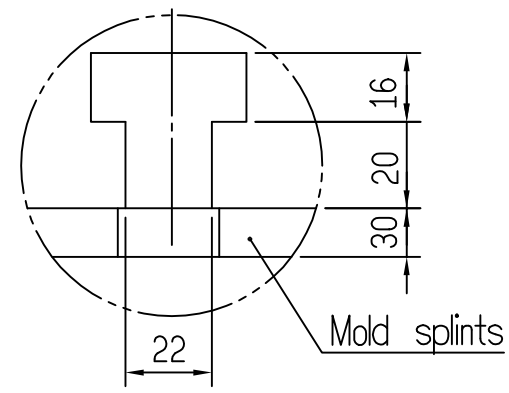

"F" is 0, -75, -100, -125, -150

*when shot position is 0, ladle cup is restricted. (dosing furnace does not apply)

Re<01>: 180T~420T mold splints are optional.